

A Simulation of Berth Scheduling Problem for Container Terminals Considering Internal Trucks and Vessels Arrival Time

Maulin Masyito Putri^{a)}, Muhammad Faisal Ibrahim^{b)}, and Rifki Ratih Triwardani^{c)}

Department of Logistics Engineering Departement, Universitas Internasional Semen Indonesia, PT. Semen Indonesia (Persero) Tbk. Area, Jl. Veteran, Sidokumpul, Gresik, Jawa Timur, Indoensia, 61122

^{a)} Corresponding author: maulin.putri@uisi.ac.id

^{b)} Muhammad.ibrahim@uisi.ac.id

^{b)} rifki.triwardani16@student.uisi.ac.id

Abstract. This research develops a berth scheduling simulation model to solve the Berth Scheduling Problem at a container terminal. Berth scheduling is influenced by the vessel's arrival time, because it will affect the availability of the quay and material handling. The vessel needs material handling for loading and unloading process in container terminal, there are quay crane and internal trucks. The internal truck moves the unloading containers from quay to the container yard and the loading containers from container yard to the quay. The quay crane will start loading and unloading when the internal trucks arrive at the quay. It often causes the quay cranes and vessels to wait for loading unloading process. In addition, this will have an impact on the berthing time of the vessel and the waiting time for other ships that will berth. This research develops a berth scheduling simulation by considering the arrival time of the vessels and internal trucks to get the vessel's berthing schedule and assign the QC by minimizing waiting time and berthing time.

INTRODUCTION

In recent years, there has been an increase in the number of containers in all Indonesia's container ports. In 2019, it was recorded that 14.7 million TEUs of containers were served by Indonesia's container port, an increase of 4.79% from 2018 [1]. It's supported by the government policies for developing Indonesia's maritime infrastructure and business processes. These policies are expected to minimize dwelling time or to minimize the length of time ships are docked for loading and unloading to increase container port service capacity. To achieve this goal, it is necessary to have operational efficiency for Indonesia's container port services.

There are five important parts in the operation of a container port, they are gate, container yard (CY) or storage yard (SY), transport, dock (quay) and berth as described in Fig. 1. [2]. Gate is the entrance and exit of customer trucks to or from CY and dock. CY is a temporary storage for containers to be loaded or unloaded to or from the vessel. Transport is a truck or material handling equipment such as an Automated Guide Vehicle (AGV), internal trucks, forklifts, etc. In this area, there is stacking crane equipment that can receive / deliver vehicles from / to trucks and vehicles to the quay. Stacking cranes also carry containers in CY. The dock is the place for loading and unloading ships with a quay crane (QC) tool. QC unloads the unloading container (domestics or international containers) and loads them on the internal trucks for transferring the containers to CY. And the berth area is a pool adjacent to the quay and is used to dock the vessels.

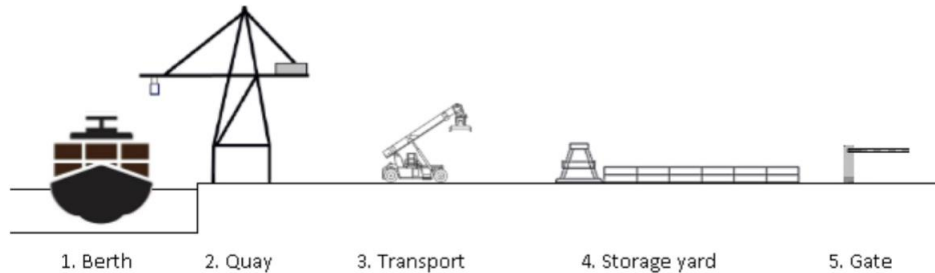

FIGURE 1. Container Port Parts (Source: Carlo et al., 2014)[2]

In the quay area, there is process for loading and unloading containers to and from the vessel and process for loading and unloading containers from and to internal trucks (transport). The loading unloading process is assisted by one or more QC for each ship. QC will work when the ship is ready to be unloaded or loaded and the truck is ready in loading and unloading position. The process of loading and unloading vessels is carried out in accordance with the availability of the quay and material handling. To minimize accidents, some Indonesia's container ports only allow internal trucks (port-owned trucks) that are allowed to enter the port area and to avoid queuing for trucks at the quay area. The ship's arrival schedule will affect the number of QC that will be used to serve each ship and the number of internal trucks that will serve each QC on each ship.

There are some previous studies related to berth allocation and scheduling. Some research integrating berth allocation and QC assignment and scheduling (BACAP & BACASP) [3] [4] [5] [6]. Turkogullari, et al. develop the BACAP models use linear programming model with integer 0-1, and the BACASP models use linear programming with mixed integers [3]. They have developed the BACASP model from previous studies which only cover 15 ships to 60 ships [3]. Correcher, et al proposes the metaheuristics approach based on Biased Random-key Genetic Algorithm with memetic characteristics and several Local Search procedures in BACAP and BACASP [4]. That approach can find the optimal solutions for up to 100 ships in an instance [4]. Malekhamadi, et al present an integer programming model for BACASP [5]. They use random topology particle swarm optimization algorithm (RTPSO) to solve BACASP at the large-size instances [5]. Han, et al use a mixed integer programming model and simulation based Genetic Algorithm (GA) search procedures to solve the BACASP [6]. They address berth and quay crane problems in a simultaneous way, with some uncertainty in time, like vessel arrival time and container handling time [6]. Arango, et al focus on BACASP and yard allocation problems to minimize the total service time or operating time [7]. They use optimization model to solve the problem and develop a genetic algorithm to solve the mixed integer model under three different situations in a Spanish Port [7].

Hammouti, et al have compared 3 models of berth Allocation Problem (BAP), namely dynamic and discrete berth allocation problem model (DDBAP), dynamic and continuous berth allocation problem model (DCBAP), and dynamic and hybrid berth allocation problem model (DHBAP) to find out which models can be used as a standard model for all type of terminal layouts and gives most satisfactory results at the level of minimization of ships turnaround time in the port [8]. By using CPLEX, Himmaouti, et al (2020) can find out that DHBAP is the best model that is qualified to be applied in all types of terminal layouts [8].

This research will simulate the berth scheduling to determine to minimize the waiting time and the berthing time of vessels. This study determines the berthing location of vessels based on the vessel's arrival time and the availability of QC and determines the optimal number of internal trucks.

PROBLEM DEFINITION

There are ten QC on the quay for loading unloading containers from or to ship. There are 5 units QC on the international quay and five units on the domestic quay. The distance between QC is 100 m. The LOA (length over all) of the ship determines the number of QCs serving the ship. The ship with LOA less than or equal to 225 meters ($LOA \leq 225$) are served by one QC, while ships with LOA more than 225 meters ($LOA > 225$) are served by 2 QC. There are two types of containers, loading container and unloading container. After the ship has docked at the quay, the QC unloads the unloading containers and transferring them to the internal truck for transfer and storage at CY. After all the unloading containers have been moved to CY, the internal truck carries the loading containers from CY to QC to be loaded to the ship. The quay layout is described in Fig. 2 and the distance matrix between QC, CY and

garage is shown in Table 3. The port manages trucks with dedicated dispatching strategy to QC. One QC is served by seven trucks and a truck will be assigned to a QC until finish serve a ship. The starting point of the trucks is garage. When the truck is finished serving the ship will return to the garage. The speed of internal trucks is constant 20 km/h.

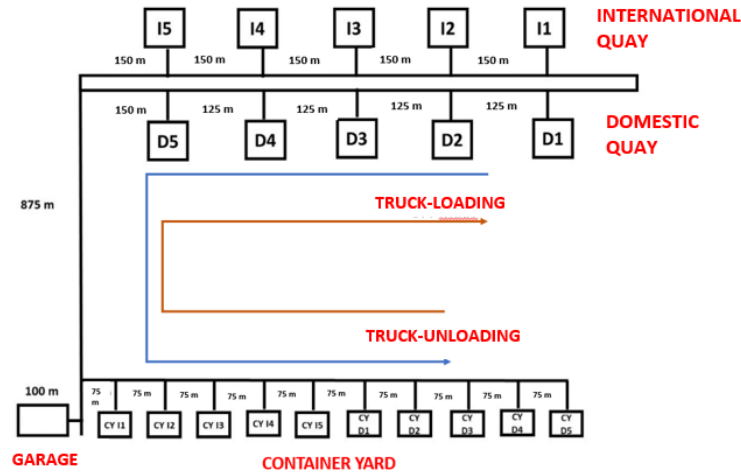

FIGURE 2. Container Terminal Layout

TABLE 1. Distance Matrix (Meter)

To\From	CY I1	CY I2	CY I3	CY I4	CY I5	CY D1	CY D2	CY D3	CY D4	CY D5	Garage
I1	1755	1830	1905	1980	2055	2130	2205	2280	2355	2430	1725
I2	1605	1680	1755	1830	1905	1980	2055	2130	2205	2280	1575
I3	1455	1530	1605	1680	1755	1830	1905	1980	2055	2130	1425
I4	1305	1380	1455	1530	1605	1680	1755	1830	1905	1980	1275
I5	1155	1230	1305	1380	1455	1530	1605	1680	1755	1830	1125
D1	1990	2065	2140	2215	2290	2365	2440	2515	2590	2665	1625
D2	1865	1940	2015	2090	2165	2240	2315	2390	2465	2540	1500
D3	1740	1815	1890	1965	2040	2115	2190	2265	2340	2415	1375
D4	1615	1690	1765	1840	1915	1990	2065	2140	2215	2290	1250
D5	1490	1565	1640	1715	1790	1865	1940	2015	2090	2165	1125
Garage	175	250	325	400	475	550	625	700	775	850	0

MODEL

Conceptual Model

The conceptual model of this research is described in the Activity Cycle Diagram (ACD) as in Fig. 3. ACD describes the sequence of processes that occur during the loading and unloading process of containers. When the vessel arrives, the vessel will wait to determine which quay area and QC will serve the vessel. After that, the vessel will berth at the quay and setup the loading and unloading process. Furthermore, the containers will be unloaded using QC and request the internal trucks from the garage to move to the QC. The containers will be loaded by internal trucks and transferred to CY. The containers to be unloaded are then stacked by CY's crane in CY. If there are still unloading containers on board, the internal trucks will immediately return to QC. If there are not unloading containers on vessel, the truck will load at CY and deliver the containers to QC to be loaded on the vessel. When all

the loading containers have been loaded on the vessel, the internal truck will return to the garage and the vessel is ready to take off the berth.

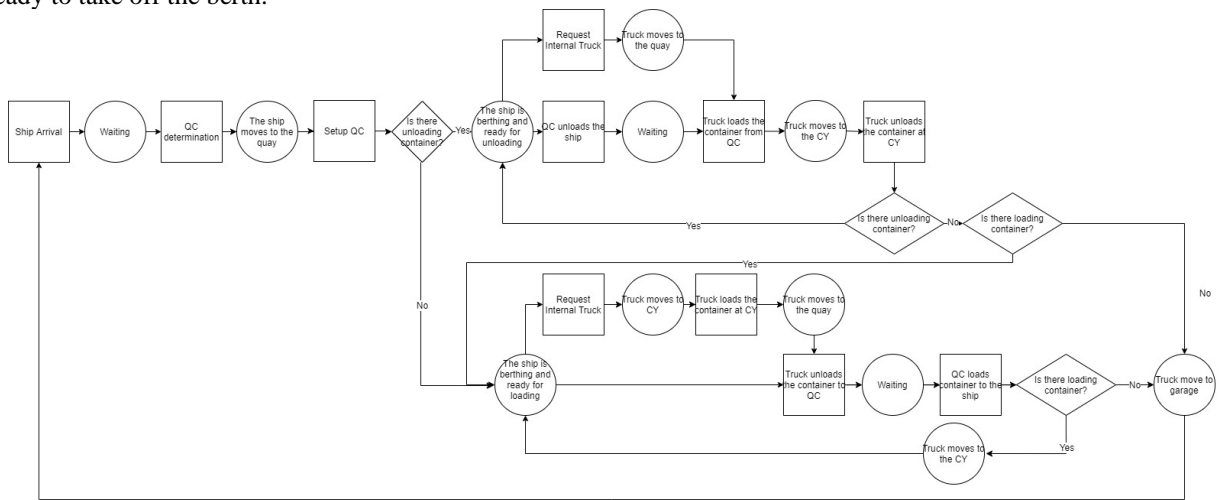

FIGURE 3. ACD of Model Conceptual

Simulation Model

The simulation model consists of two sub-models, there are the quay sub-model (Fig. 4) and the CY sub-model (Fig. 5). The quay sub-model simulates the ships and the internal trucks arrival, the vessels berthing process, the loading and unloading process of QC, the loading and unloading process of internal trucks and the movement of internal trucks to CY. Meanwhile, the CY sub-model simulates the arrival of internal trucks from the quay area, the loading and unloading process of internal trucks and ASC and the movement of internal trucks to the quay area.

When the internal truck is idle, the internal truck will go to the garage to wait for the assignment. If there is an unloading assignment at the quay area, then the truck will go to the quay area from the garage. If there is an unloading assignment at CY, the internal truck will go to CY from the garage.

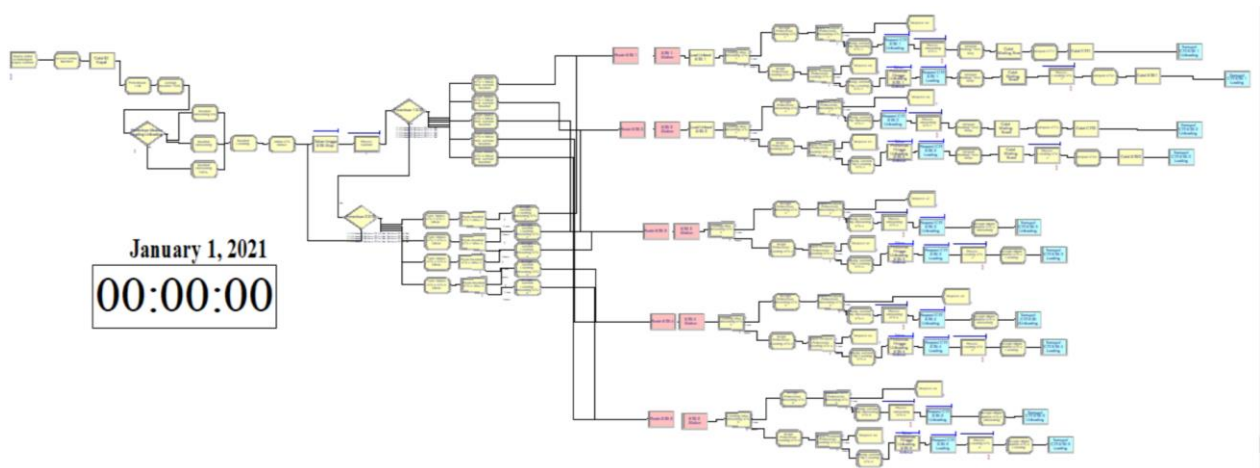

FIGURE 4. Quay Sub-Model

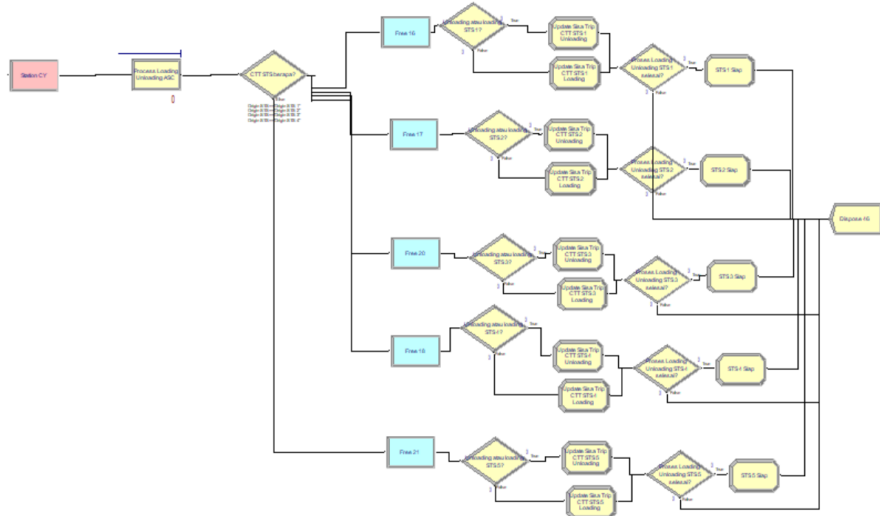

FIGURE 5. CY Sub-Model

After doing simulation modeling and running simulations, the next step is to determine the number of running replications. Running the simulation once, may not necessarily produce a value that is representative of the real system. In this replication process, it is done by trying to simulate with 10 replications for the initial replication and calculating the estimated population average interval (half-width) based on the simulation replication sample. From initial replication, the standard deviation is 2908.9. With $\alpha=0.05$ and $(t_{n-\frac{1\alpha}{2}}) = 2.2622$, so the half-width (hw) value is:

$$hw = \frac{(t_{n-\frac{1\alpha}{2}})s}{\sqrt{n}} \quad (1)$$

$$hw = \frac{2,26 \times 2909.9}{\sqrt{10}} = 2081.67$$

With $\alpha=0.05$ and $z\frac{\alpha}{2} = 1.96$, so the number of replications is:

$$n' = \left[\frac{(z\frac{\alpha}{2}) \times s}{\beta} \right]^2 \quad (2)$$

$$n' = \left[\frac{1,96 \times 2909.9}{2081.67} \right]^2 = 7.507 \approx 8$$

RESULT AND DISCUSSION

We simulate six vessels with seven working days. The berth scheduling with the allocation QC described in Fig. 6, while the simulation result described in Table 2. The vessel berth directly when arrived port. The first vessel docked immediately when it arrives in container terminal area. It's because all QC and internal trucks are available. When the vessel docked, seven internal trucks from the garage headed to QC D1. When one internal truck arrives at the loading location, the QC unloads the container and loads it to the internal truck. Then the internal truck will move to CY and the second arrival internal truck will occupy the loading position to carry out the process like the previous truck.

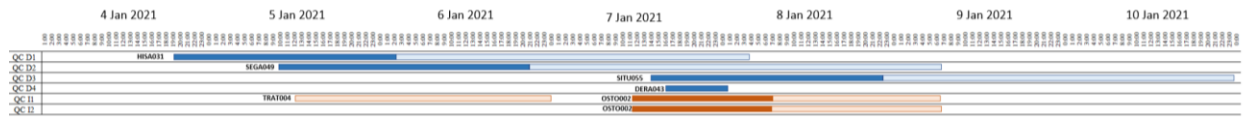

FIGURE 5. Berth Scheduling

TABLE 2. Simulation Result

Ship ID	ATQ	QC ID	Internal Truck ID								Departure Time
HISA031	11/29/2019 18:06	QC D1	T1	T2	T3	T4	T5	T6	T7	12/3/2019 3:24	
SEGA049	11/30/2019 8:56	QC D2	T8	T9	T10	T11	T12	T13	T14	12/4/2019 6:10	
TRAT004	11/30/2019 19:36	QC II	T15	T16	T17	T18	T19	T20	T21	12/1/2019 23:28	
OSTO002	12/2/2019 10:30	QC II	T15	T17	T19	T21	T23	T25	T27	12/4/2019 6:03	
		QC I2	T16	T18	T20	T22	T24	T26	T28		
SITU055	12/2/2019 13:00	QC D3	T29	T30	T31	T32	T33	T34	T35	12/5/2019 23:00	
DERA043	12/2/2019 15:12	QC D4	T36	T37	T38	T39	T40	T41	T42	12/3/2019 0:12	

The container terminal needs 4 QC in domestic dock and 2 QC in international dock for serving 4 domestic ships and 2 international vessels. With dedicated dispatching strategy (7 internal trucks for 1 QC), the container terminal needs 42 internal trucks.

TABLE 3. Waiting Time Result

Ship ID	QC		Internal Truck	
	Total <i>WT</i> _{QC} (Minute)	Average of <i>WT</i> _{QC} (Minute)	Average of <i>WT</i> _{QC,t} (Minute)	Average Waiting Time in CY (Minute)
HISA031	207.925	0.180	7.680	0.152
SEGA049	232.225	0.176	5.602	0.009
TRAT004	12.790	0.039	11.585	0.042
OSTO002	22.605	0.076	18.349	0.298
	25.605	0.087	19.711	0.367
SITU055	109.195	0.090	7.833	0.024
DERA043	15.590	0.092	1.019	0.000

From Table 3, we can analyze that by adding the number of QC assigned to a ship, it will speed up the loading and unloading process on the ship. So, we can minimize the waiting time of QC and the waiting time of internal truck in QC and in CY. And the most important is the container terminal can minimize the berthing time of ship and increase their utility with serve more ship. Internal truck dedicated dispatching strategy also affects to the waiting time of QC.

CONCLUSION

Based on the research results, it can be concluded that berth scheduling by considering the arrival time of vessel and internal truck can minimize QC waiting time or idle time and internal truck waiting time. So, they can minimize the berthing time and increase their utility with serve more vessel. In addition, we can use this simulation to evaluate internal truck dispatching strategies by increasing or decreasing the number of internal trucks per QC with a little bit model development. From the research results, it is known that 7 internal trucks result in high total waiting time. So, it is necessary to have a strategy to increase the number of internal trucks to serve QC. For further research, it is necessary to consider the route of the internal truck to minimize travel time and the container yard template.

ACKNOWLEDGMENTS

The authors would like to say thanks to the reviewers for any suggestions to improve the quality of this paper and Community Service of Universitas Internasional Semen Indonesia for the financial support of this study.

REFERENCES

1. Data, C., Indonesia Container Port Throughput, 4th November 2020. [Online]. Available: <https://www.ceicdata.com/en/indicator/indonesia/container-port-throughput>.
2. Carlo, H. J., Vis, I. F.A., and Roodbergen, K. J., Storage yard operations in container terminals : Literature overview, trends and research directions, *European Journal of Operational Research*, Vol. 235, 2014, p. 412–430.
3. Türkog˘ulları, Y. B., Taşkın, Z. C., Aras, N., Altinel, K., Optimal berth allocation and time-invariant quay crane assignment in container terminals, *European Journal of Operational Research*, 235 (1), 2014, pp. 88-101.
4. Correcher, J. F. and Alvarez-Valdes, R., A Biased Random-Key Genetic Algorithm for the time-invariant Berth Allocation and Quay Crane Assignment Problem, *Expert Systems With Applications*, Vol 89, 2017, pp. 112-128.
5. Malekhamdi, A., Alinaghian, M., Hejazi, S. R., and Saidipour, M. A. A., Integrated continuous berth allocation and quay crane assignment and scheduling problem with time-dependent physical constraints in container terminals, *Computers & Industrial Engineering*, Vol 147, 2020, pp. 106672.
6. Han, X.-l., Lu, Z.-q., and Xi, L.-f., A proactive approach for simultaneous berth and quay crane scheduling problem with stochastic arrival and handling time, *European Journal of Operational Research*, Vol 207 (3), 2010, pp. 1327-1340.
7. Arango, C., Corte´s, P., and Escudero, A., Genetic Algorithm for the Dynamic Berth Allocation Problem in Real Time, in *Swarm Intelligence and Bio-Inspired Computation Theory and Applications*, Elsevier, 2013, pp. 367-383.
8. Hammoutia, I. E. and Lajjamb, A., Comparison of Planning Models for Dynamic Berth Allocation Problem Using A Sailfish-based Algorithm, *Procedia Computer Science*, Vol. 176, 2020, p. 3112–3120.
9. Rodríguez, I. C., Izquierdo, C. E., Batista, B. M., Aguilar, R. M., & Vega, J. M., Simulation-optimization for the management of the transshipment operations at maritime container terminals, *Expert Systems with Applications*, Vol. 139, 2019, p. 112852.
10. Sammarra, M., Cordeau, J., Laporte, G., & Monaco, M., A tabu search heuristic for the quay crane scheduling problem, *Journal of Scheduling*, Vol. 10(4-5), 2007, pp. 327-336.
11. Tang, G., Wang, W., Song, X., Guo, Z., Yu, X., & Qiao, F., Effect of entrance channel dimensions on berth occupancy of container terminals, *Ocean Engineering*, Vol. 117, 2016, pp. 174-187.